



Avaya 3920 Wireless Telephone

User's Guide

16-603439
Issue 2
December 2010

Notice

Every effort was made to ensure that the information in this book was complete and accurate at the time of printing. However, information is subject to change.

Federal Communications Commission Statement

This equipment has been tested and found to comply with Part 15 of the FCC Rules. These limits are designed to provide reasonable protection against harmful interference when the equipment is operated in a commercial environment. This equipment generates, uses, and can radiate radio-frequency energy and, if not installed and used in accordance with the instructions, may cause harmful interference to radio communications. Operation of this equipment in a residential area is likely to cause harmful interference, in which case the user will be required to correct the interference at his own expense. This system is Class B compliant in some configurations.

Canadian Department of Communication (DOC) Interference Information

This digital apparatus does not exceed the Class A limits for radio noise emissions set out in the radio interference regulations of Industry Canada.

Le Présent Appareil Numérique n'émet pas de bruits radioélectriques dépassant les limites applicables aux appareils numériques de la class A prescrites dans le règlement sur le brouillage radioélectrique édicté par le Industrie Canada.

Preventing Toll Fraud

"Toll fraud" is the unauthorized use of your telecommunications system by an unauthorized party (for example, a person who is not a corporate employee, agent, subcontractor, or working on your company's behalf). Be aware that there may be a risk of toll fraud associated with your system and that, if toll fraud occurs, it can result in substantial additional charges for your telecommunications services.

The final responsibility for securing both this system and its networked equipment rests with you – an Avaya Inc. system administrator, your telecommunications peers, and your managers. Avaya Inc. does not warrant that this product or any of its networked equipment is either immune from or will prevent either unauthorized or malicious intrusions. Avaya Inc. will not be responsible for any charges, losses, or damages that result from such intrusions.

Avaya Fraud Intervention

If you suspect you are being victimized by toll fraud and you need technical support assistance, call Avaya Global Support Services at **1 800 628-2888**.

Warranty

Avaya Inc. provides a limited warranty on this product. Refer to the "Limited Use Software License Agreement" card provided with your package.

Trademarks

PARTNER is a registered trademark of Avaya Inc. in the U.S. and other countries.

Customer Support

If you need assistance when programming or using your system, contact your local Authorized Dealer or call Avaya Global Support Services at **1 800 628-2888**. Consultation charges may apply.

Avaya Web Page

For information about Avaya products and service, go to www.avaya.com. For the most current version of this document, go to www.avaya.com/support.



Important Safety Instructions

The following list provides basic safety precautions that should always be followed when using your telephone equipment.

1. Read and understand all instructions.
2. Follow all warnings and instructions marked on the product.
3. Unplug all telephone connections before cleaning. **DO NOT** use liquid cleaners or aerosol cleaners. Use a damp cloth for cleaning.
4. This product should be serviced by (or taken to) a qualified repair center when service or repair work is required.
5. **DO NOT** use this product near water, for example, in a wet basement location.
6. **DO NOT** place this product on an unstable cart, stand or table.
7. Never push objects of any kind into slots or openings as they may touch dangerous voltage points or short out parts that could result in a risk of fire or electric shock. Never spill liquid of any kind on the product.
8. **DO NOT** use the telephone to report a gas leak in the vicinity of the leak.

Contents

1	Introduction	7
	Welcome	7
	Organization	8
	Conventions	8
	Related Documents.....	9
2	Installing the Telephone	11
	Overview	11
	Select Base Unit Location	13
	Install the Base Unit on a Desktop	14
	Install the Base Unit on a Standard Wall Plate	16
	Install the Base Unit Directly on a Wall	19
	Apply Power to the Charger Unit.....	23
	Mount the Charger Unit on a Wall (Optional)	24
	Install the Handset Battery	25
	Charge the Battery for the First Time.....	27
	Charge the Spare Battery	28
	Install a Headset (Optional).....	30
	Attach the Belt Clip to the Handset	31
	Remove the Belt Clip from the Handset.....	33
3	About Your Telephone	35
	Overview	35
	Handset.....	36
	Base Unit.....	41
	Charger Unit.....	42
	Clean the Charger Unit Contacts.....	43
	Battery	44
	Low Battery Indications	44

4 Using Your Telephone	45
Overview	45
Handset Modes	45
Handling Calls	46
Make a Call.....	46
Answer a Call.....	46
Make an Intercom Call.....	47
Answer an Intercom Call.....	47
Place a Call on Hold	47
Transfer a Call	47
Conference a Call	48
Mute a Conversation.....	48
Changing Handset Settings.....	49
Change Earpiece Volume.....	49
Change Ring Type and Volume.....	49
Set Vibrate Mode	50
Turn Ringer Off	50
Set Silent Alert.....	50
Set the End of Range Alarm	51
A Troubleshooting	53
B Specifications	57
C Accessories	59

1 Introduction

Welcome

This guide provides instructions on how to install and use your Avaya 3920 Wireless Telephone. The Avaya 3920 Wireless Telephone is specific to the Avaya PARTNER Communications System and Avaya IP Office Essential Edition - PARTNER Version. Unlike consumer-type wireless telephones, which are typically connected to analog interfaces, the Avaya 3920 Wireless Telephone offers full access to the features of the PARTNER system, including two dedicated intercom buttons plus six line/feature buttons with LED-status indication.

The Avaya 3920 Wireless Telephone uses DECT 6.0 technology to provide crystal-clear, high-quality voice communication. Unlike other wireless technologies (such as ISM spectrum), DECT 6.0 uses a dedicated frequency that is free from interference from other devices.

The Avaya 3920 Wireless Telephone is not only a single-cell wireless telephone. The system can be expanded with repeaters to cover larger areas without the need of additional wiring. This flexible expansion of the coverage area makes the Avaya 3920 Wireless Telephone cost effective for small installations, while at the same time providing the capability for seamless telephony in larger areas.

Up to six repeaters can be linked with a single base unit to increase the coverage area of the Avaya 3920 Wireless Telephone, making crystal-clear communication possible in areas that were hard to reach without installing a complex, multicell telephone system.

In the U.S. and Canada, DECT 6.0 provides a maximum of five channels with 12 full-duplex slots. The technology embedded in the Avaya 3920 Wireless

Telephone can support a maximum of five channels with six full-duplex slots, providing you with a total of 30 available channels/slots.

DECT 6.0 is extremely easy to install since frequency and channel selection are done automatically. As long as the maximum number of devices is not exceeded, DECT 6.0 will provide trouble-free functionality.



This chapter explains how this guide is organized, shows the typographical conventions used, and provides the Avaya Support Center web site to access for additional documentation.

Organization

This guide is organized as follows:

- **Chapter 1, “Introduction”** provides a brief description of the contents of each chapter, the typographical conventions used, and the Avaya Support Center web site.
- **Chapter 2, “Installing the Telephone”** provides installation instructions.
- **Chapter 3, “About Your Telephone”** describes the handset, including operating controls and buttons; batteries; and base and charger units.
- **Chapter 4, “Using Your Telephone”** describes basic call handling operations and how to change handset settings.
- **Appendix A, “Troubleshooting”** describes performance problems and suggestions to correct the problems.
- **Appendix B, “Specifications”** provides telephone specifications.
- **Appendix C, “Accessories”** lists the accessories available for the telephone.

Conventions

- Numbers, the asterisk, and the pound sign on the dialpad are shown in a button, for example: , , or .
- **Bold** type is used to indicate buttons on the Handset, other than those on the dialpad.
- `Courier` type indicates text that appears in the handset display.

Related Documents

For additional documentation and the most current version of this document, go to the Avaya Support Center at www.avaya.com/support.

2 Installing the Telephone

Overview

This chapter explains how to install the Avaya 3920 Wireless Telephone. The sections provided in this chapter are as follows:

- 1 “Select Base Unit Location” on page 13.
- 2 “Install the Base Unit on a Desktop” on page 14.
- 3 “Install the Base Unit on a Standard Wall Plate” on page 16.
- 4 “Install the Base Unit Directly on a Wall” on page 19.
- 5 “Apply Power to the Charger Unit” on page 23.
- 6 “Mount the Charger Unit on a Wall (Optional)” on page 24.
- 7 “Install the Handset Battery” on page 25.
- 8 “Charge the Battery for the First Time” on page 27.
- 9 “Charge the Spare Battery” on page 28.
- 10 “Install a Headset (Optional)” on page 30.
- 11 “Attach the Belt Clip to the Handset” on page 31.

The Avaya 3920 Wireless Telephone is packaged with this installation and use guide and the components shown below. If any of these items are missing or damaged, contact your System Administrator.

Figure 1: Avaya 3920 Wireless Telephone Components

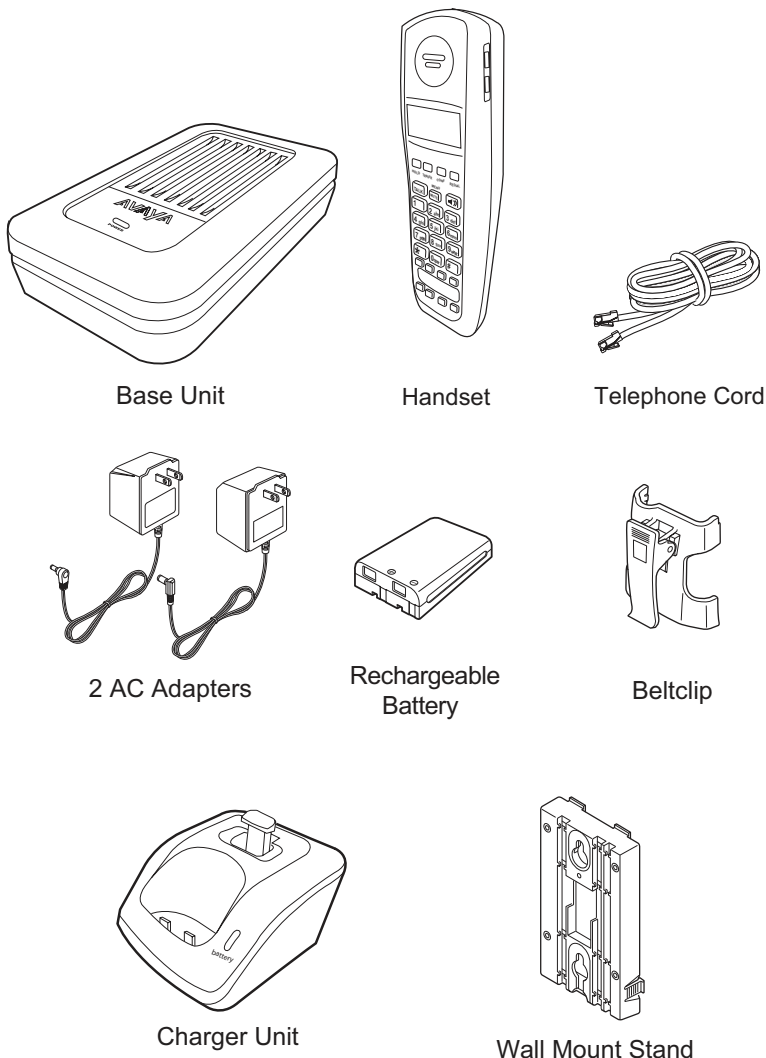

Select Base Unit Location

- Select a location that is not subject to excessive heat or humidity.
- Determine if the base unit will sit on your desk or be wall mounted.
- Place the base unit near a standard 120VAC outlet and within reach of a telephone jack that is connected to the PARTNER system (that is, PARTNER ACS or Avaya IP Office Essential Edition - PARTNER Version). Avoid a location that is surrounded by metal surfaces. Make sure this outlet cannot be turned off by a switch.

**WARNING:**

If the base unit is installed in a separate building from the PARTNER system, you must install In-Range Out of Building (IROB) protectors. The IROB used with the Avaya 3920 Wireless Telephone is Module 146D (IROB Two) Dual IROB. To order an IROB, contact your local Authorized Dealer.

- Place the base unit away from any electrical component, such as PCs, monitors, other telephones, and the PARTNER system.
- If more than one unit is being installed, each base unit must be placed at least 15 feet apart.
- Keep the base unit and handset away from sources of electrical noise, such as motors and fluorescent lighting. For more information about installation (including the positioning of base units and the installation of repeaters), please refer to the *Avaya 3920 Wireless Telephone Planning and Installation Guide*.

**WARNING:**

The Avaya 3920 Wireless Telephone handset and base unit are designed for indoor use and installation. These devices are not water proof and are not designed for use in wet or moist environments. The repeaters have an IP54 (weather resistant) weather protection rating. The repeaters are protected against dust and weather hazards (such as rain and sleet) and sprayed oil and noncorrosive coolants.

Install the Base Unit on a Desktop

This section provides procedures to install the base unit on a desktop or table.

If you want to mount the base unit on a wall, go to [“Install the Base Unit on a Standard Wall Plate” on page 16](#) or [“Install the Base Unit Directly on a Wall” on page 19](#).

- 1 Plug the RJ-45 end (the larger connector) of the 14-foot telephone cord into the “Line In” jack on the base unit.
- 2 Plug the RJ-11 end (the smaller connector) of the telephone cord into the telephone jack that is connected to your PARTNER system.

Figure 2: Connect Telephone Cord

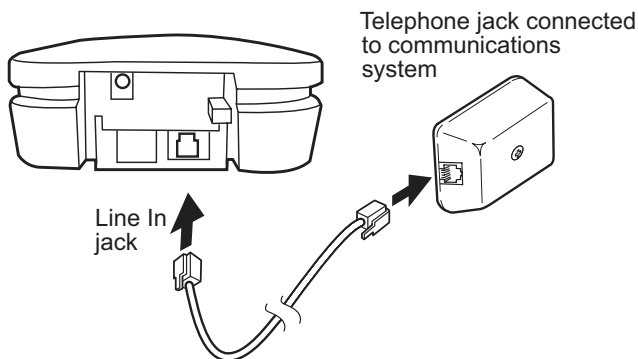

- 3 Plug the AC adapter cord into the AC adapter input jack on the base unit.
- 4 Plug the AC adapter into a standard 120VAC wall outlet. Make sure this outlet cannot be turned off by a switch.

Figure 3: Connections to Base Unit

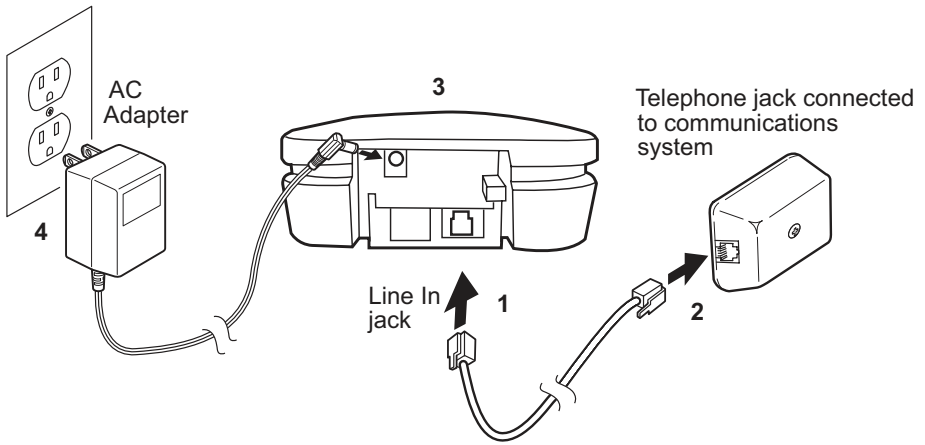

- 5 Check to see that the power LED is on.

Install the Base Unit on a Standard Wall Plate

This section provides procedures to mount the base unit on the wall if a standard wall plate, with a telephone jack connected to the PARTNER system, is installed in the wall.

If you want to mount the base unit on the wall and a standard wall plate is not installed, go to [“Install the Base Unit Directly on a Wall” on page 19.](#)

⚠ CAUTION:

Do not mount the base unit on the ceiling.

- 1 To attach the wall mount stand to the base unit, slide the wall mount stand into the notches at the top of the base unit. Then pull the wall mount stand down and snap it into place.

Figure 4: Attach Wall Mount Stand to Base Unit

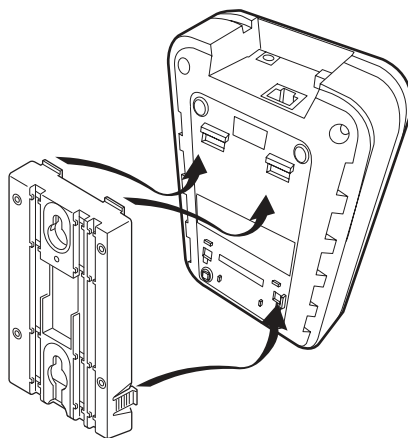

- 2 Plug the RJ-45 end (the larger connector) of the 14-foot telephone cord into the "Line In" jack on the base unit.
- 3 Plug the AC adapter cord into the AC adapter input jack on the base unit.

Figure 5: Plug Cords into Base Unit

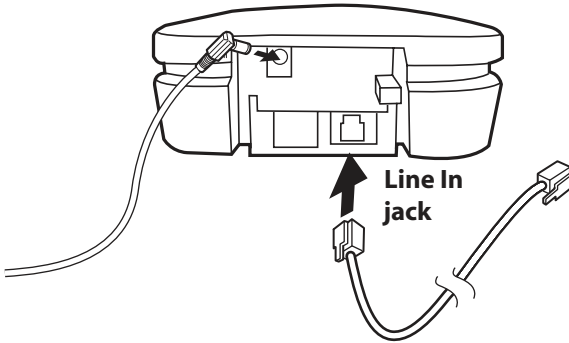

- 4 Place the AC adapter cord and the telephone cord inside the molded channels of the wall mount stand.
- 5 Plug the RJ-11 end (the smaller connector) of the telephone cord into the telephone jack in the wall plate.

Figure 6: Place Cords in Molded Channels

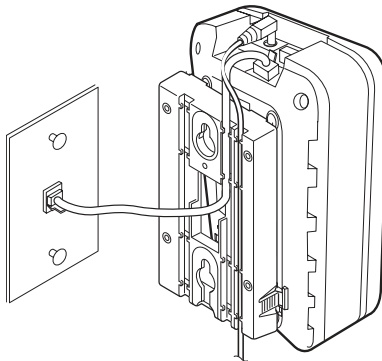

- 6 Place the base unit on the posts of the wall plate and pull down until the base unit is firmly seated.

Figure 7: Mount Base Unit on Wall Plate

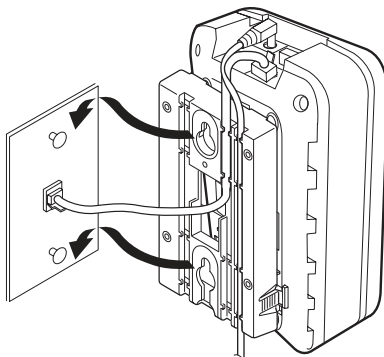

- 7 Plug the AC adapter into a standard 120VAC wall outlet. Make sure this outlet cannot be turned off by a switch.

Figure 8: Plug AC Adapter into Wall Outlet

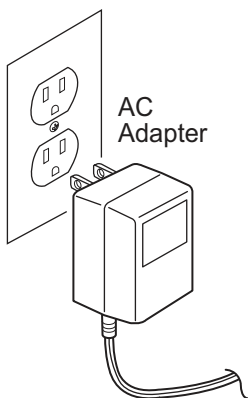

- 8 Check to see that the power LED is on.

Install the Base Unit Directly on a Wall

This section provides procedures to mount the base unit directly on a wall if a standard wall plate is not installed. Use #10 screws and, if necessary, anchoring devices that are suitable for the wall material where the base unit will be placed.

⚠ CAUTION:

Do not mount the base unit on the ceiling.

- 1 Insert two mounting screws into the wall 3 and 15/16 inches apart. Allow about 3/16 of an inch between the wall and screw heads for mounting the base unit.

Figure 9: Insert Mounting Screws

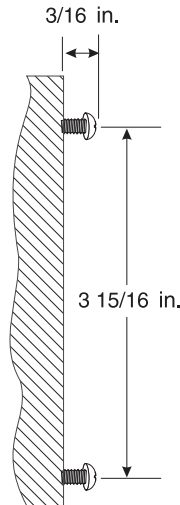

- 2 To attach the wall mount stand to the base unit, slide the wall mount stand into the notches at the top of the base unit. Then push the wall mount stand down and snap it into place.

Figure 10: Attach Wall Mount Stand to Base Unit

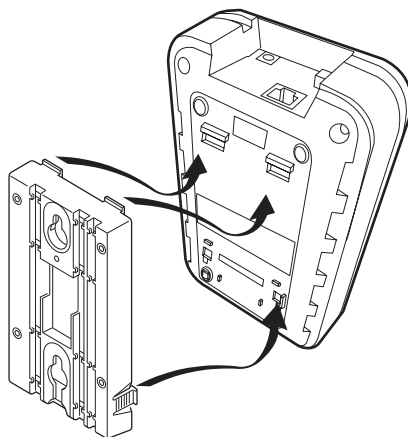

- 3 Plug the RJ-45 end (the larger connector) of the 14-foot telephone cord into the "Line In" jack on the base unit.
- 4 Plug the AC adapter cord into the AC adapter input jack on the base unit.

Figure 11: Plug Cords into Base Unit

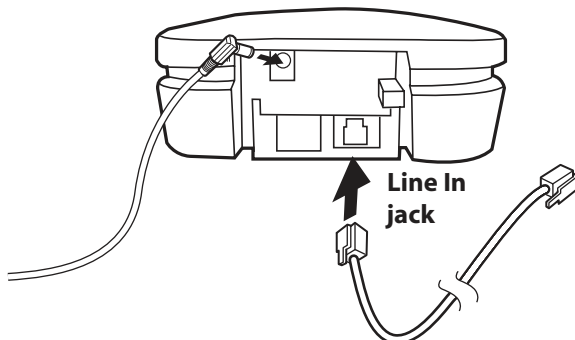

- 5 Place the AC adapter cord and the telephone cord inside the molded channels of the wall mount stand.

Figure 12: Place Cords in Molded Channels

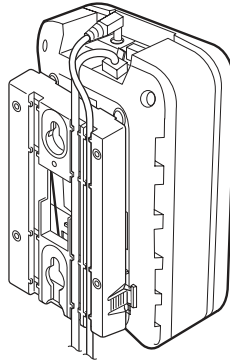

- 6 Place the base unit on the posts of the wall screws and pull down until the base unit is firmly seated.

Figure 13: Place Base Unit on Wall Screw Posts

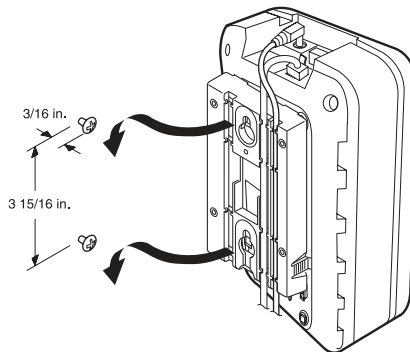

- 7 Plug the RJ-11 end (the smaller connector) of the telephone cord into the telephone jack connected to the PARTNER system.

Figure 14: Plug Telephone Cord into Telephone Jack

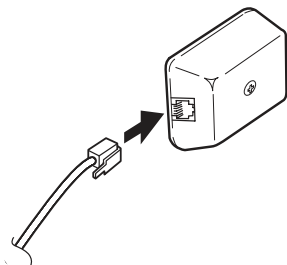

- 8 Plug the AC adapter into a standard 120VAC wall outlet. Make sure this outlet cannot be turned off by a switch.

Figure 15: Plug AC Adapter into Wall Outlet

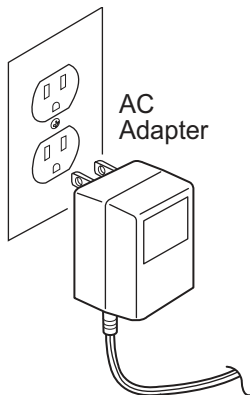

- 9 Check to see that the power LED is on.

Apply Power to the Charger Unit

- 1 Plug the AC adapter cord into the input jack on the back of the charger unit.
- 2 Wrap the AC adapter cord around the strain relief.
- 3 Plug the AC adapter into a standard 120VAC wall outlet.

NOTE ▶

Always route the power cord away from high-traffic areas, and where it cannot become chafed and create a fire or electrical hazard.

Figure 16: Apply Power to Charger Unit

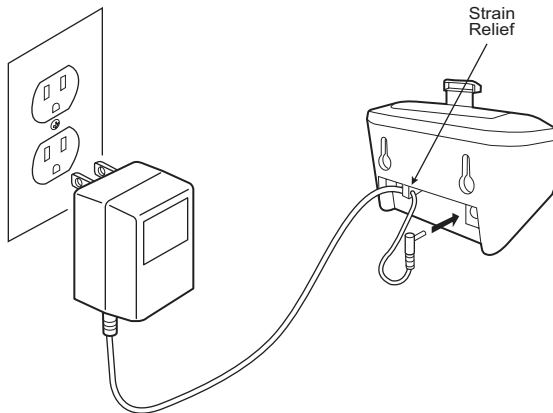

- 4 If you want to mount the charger unit on the wall, go to [“Mount the Charger Unit on a Wall \(Optional\)”](#) on page 24. Otherwise, go to [“Install the Handset Battery”](#) on page 25.

Mount the Charger Unit on a Wall (Optional)

The charger unit can be mounted directly on the wall. Use #10 screws and, if necessary, anchoring devices that are suitable for the wall material where the charger unit will be placed.

- 1 Insert two mounting screws into the wall 1 7/8 inches apart. Allow about 3/16 of an inch between the wall and screw heads for mounting the charger unit.

Figure 17: Insert Mounting Screws into Wall

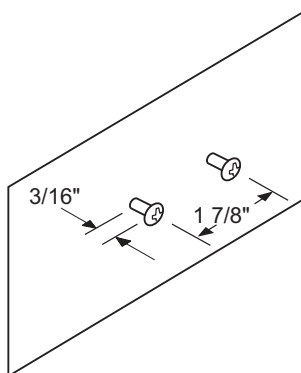

- 2 Place the charger unit on the posts of the wall screws and push down until it is firmly seated.

Figure 18: Place Charger Unit on Wall Screw Posts

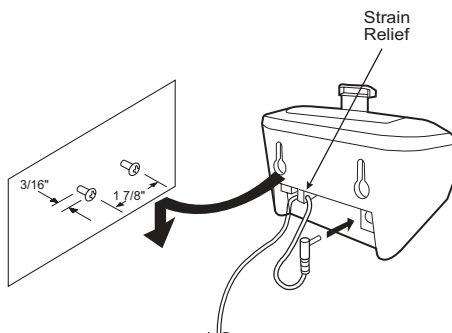

Install the Handset Battery

- 1 Remove the battery cover from the back of the handset by pressing the latch and sliding the cover down until it comes off the handset.

Figure 19: Remove Battery Cover

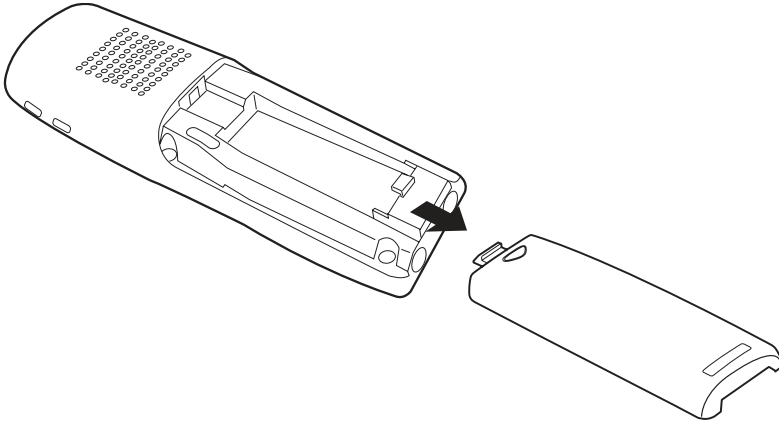

- 2 Slide the battery down into the handset.

Figure 20: Install Handset Battery

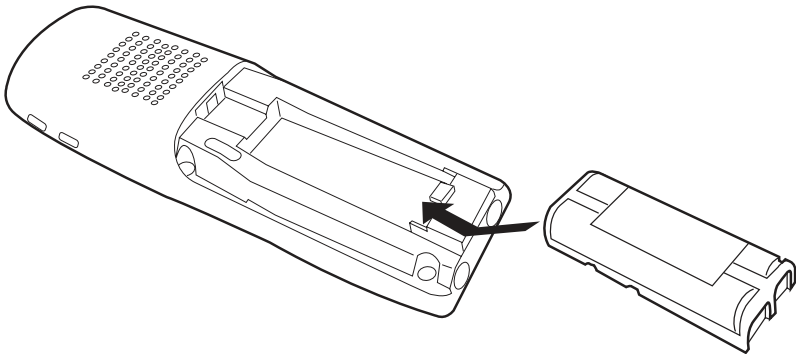

- 3 Close the battery compartment cover by sliding it up until it snaps into place.

Figure 21: Close Battery Cover

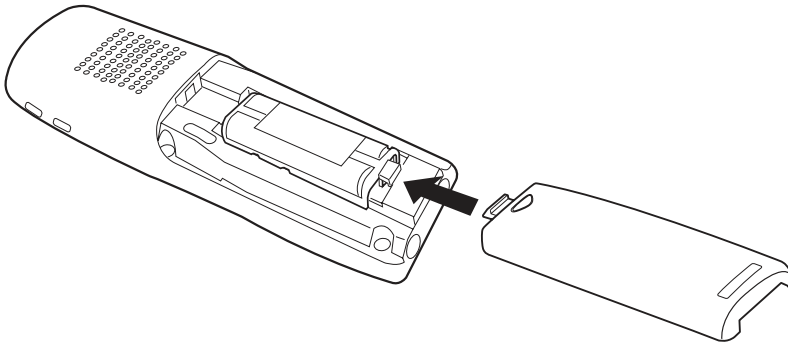

- 4 If you are using the battery for the first time, go to [“Charge the Battery for the First Time”](#) on page 27.

Charge the Battery for the First Time

Before using your handset for the first time, the battery must be continuously charged for 15 to 20 hours. (After the battery is charged for the first time, it will only take five to six hours for the battery to be fully recharged.)

- 1 Install the battery in the handset. Go to [“Install the Handset Battery”](#) on [page 25](#).
- 2 Place the handset in the charger unit.

Figure 22: Place Handset in Charger Unit

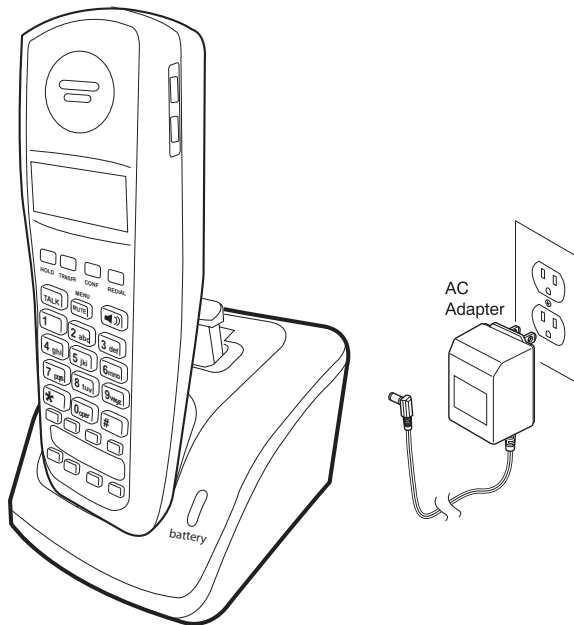

- 3 Ensure that the **Handset** LED lights blue. If it does not, make sure that the AC adapter is plugged in and that the Handset is making good contact with the charger unit.

Charge the Spare Battery

It is recommended that you have a spare battery always charging to protect against complete battery discharge. The charger unit is equipped to charge the spare battery with or without the handset in the front slot. See [Appendix C, "Accessories"](#) for information on ordering a spare battery.

- 1 Slide the spare battery into the rear slot in the charger unit until the retaining clip snaps over the top of the battery.

Figure 23: Charge Spare Battery

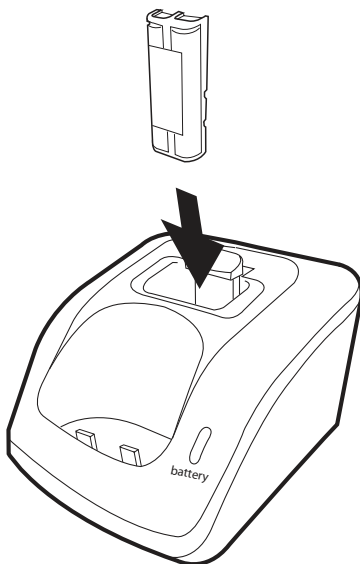

- 2 Ensure that the **Battery** indicator lights blue. If it does not, make sure that the AC adapter is plugged in and that the spare battery is making good contact with the Charger Unit.
- 3 Charge the spare battery for 15 to 20 hours.

- 4 When charging is complete, press out on the latch to remove the spare battery for use. If you don't need the spare battery immediately, leave it in the charging compartment; it will not overcharge. See information about the low battery indicator in ["Description of Icons in Handset Display"](#) on [page 40](#).

Install a Headset (Optional)

The optional headset provides a hands-free option when you use the belt clip to carry the handset and conduct a conversation. All feature operations remain the same except the handset earphone and microphone are disconnected.

- 1 Open the cover over the Headset jack that is located on the top of the Handset.
- 2 Plug in the headset.

NOTE ▶

Only use headsets especially designed or modified for use with radio frequency equipment.

Figure 24: Install Headset



Attach the Belt Clip to the Handset

You can use the belt clip to attach the handset to your belt or pocket.

- 1 Slide the clip into the tab stop.

NOTE ▶

The belt clip is designed to fit snugly onto the handset.

Figure 25: Attach Belt Clip to Handset

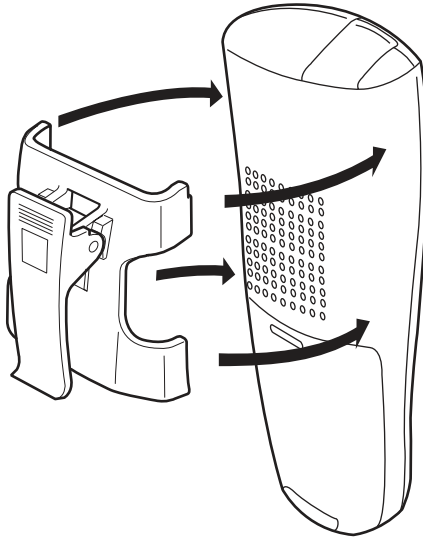

- 2 Press firmly until it snaps into place.

Figure 26: Press Belt Clip onto Handset

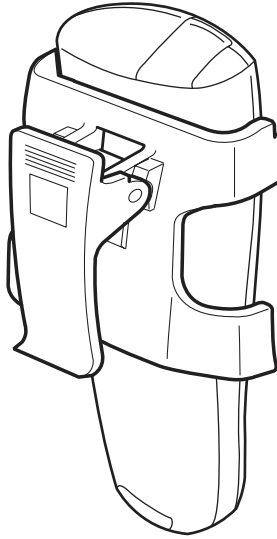

Remove the Belt Clip from the Handset

- 1 Press the retain clip in toward the belt clip blade and slide the clip up at the same time.

Figure 27: Remove Belt Clip from the Handset

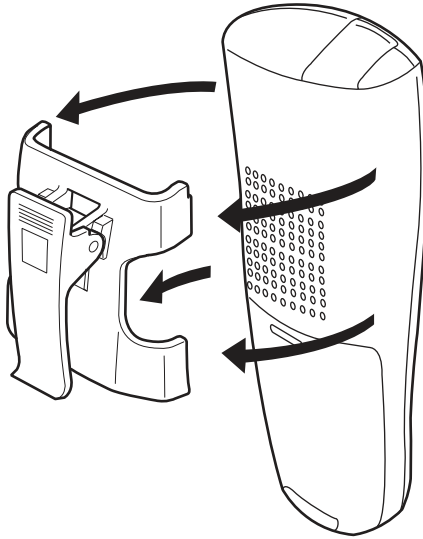

3 About Your Telephone

Overview

The Avaya 3920 Wireless Telephone is a digital telephone designed to work with your PARTNER system. It offers the mobility inherent in a wireless telephone plus access to the features and functionality of the PARTNER system. The Avaya 3920 telephone uses DECT 6.0 technology and provides the following features:

- 2-line, 16 character per line Handset Liquid Crystal Display (LCD)
- 4 displayed operation modes indicating Talk, Ringer On/Off, Battery Low, and Message Waiting
- speakerphone
- backlit dialpad
- Single button access to fixed features — Hold, Transfer, and Conference
- Feature button to access features on the PARTNER system
- Up to six programmable buttons to access features on the PARTNER system
- 2 intercom buttons
- Headset jack
- Ringer and Handset volume control
- Vibrate alert
- Base unit and charger unit

This chapter describes the Avaya 3920 Wireless Telephone handset, base unit, charger unit, and battery.

Handset

Figure 28: Avaya 3920 Wireless Telephone Handset

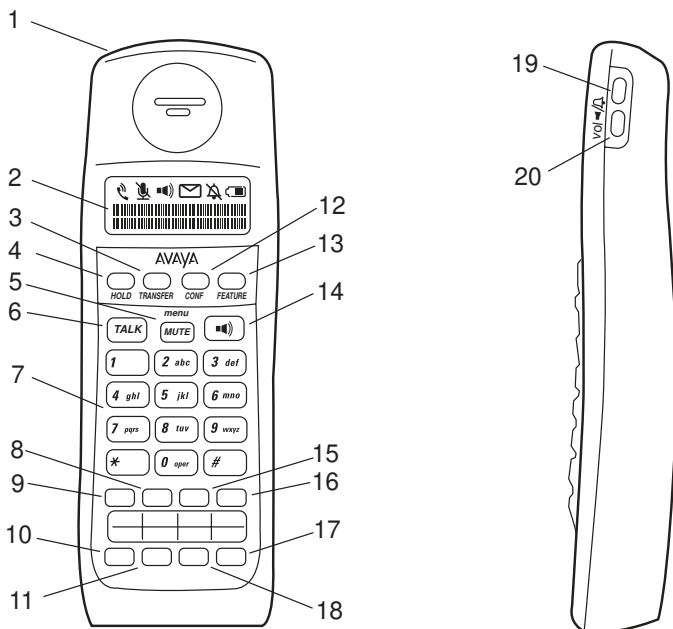

- | | |
|--------------------------|-------------------------------|
| 1 Headset Jack | 11 Programmable Button |
| 2 Handset Display | 12 Conference Button |
| 3 Transfer Button | 13 Feature Button |
| 4 Hold Button | 14 Speakerphone Button |
| 5 Mute Button | 15 Programmable Button |
| 6 Talk Button | 16 Programmable Button |
| 7 Dialpad | 17 Programmable Button |

8 Intercom Button

9 Intercom Button

10 Programmable Button



18 Programmable Button

19 Volume + Button

20 Ringer ON/OFF Volume - Button

Description of Handset Buttons

Button	Description
HOLD	Places a call on hold until you can return to it.
TRANSFER	Transfers a call to another extension.
CONF	Connects another call to a call already in progress for a three-way conversation.
FEATURE	Accesses PARTNER system features. See your System Administrator for features you can access.
TALK	Initiates, answers, and disconnects calls.
MUTE	Mutes your conversation so that the other party cannot hear your voice but you can hear theirs.
	Toggles the speaker on/off.
Dialpad	12-button dialpad for placing calls or accessing features.
Intercom buttons	Makes or answers a call to or from another extension in your system. (Shown in call-outs 8 and 9 in “Avaya 3920 Wireless Telephone Handset” on page 36.)

Button	Description
Programmable buttons	Features programmed on the programmable buttons are determined by the PARTNER system programming. See your System Administrator for information about the features programmed on your buttons.
Ringer On/Off Vol - Button (on side) vol  	Turns handset ringer on or off when not active on a call. Decreases the ringer volume when handset is out of charger unit and not active on a call. Decreases the earpiece/speakerphone when pressed during a call.
Vol + (on side)	Increases the earpiece volume when pressed during a call. Increases ringer volume when pressed when handset is out of charger unit and not active on a call.

Handset Display







The handset display has two 16-character lines and one line of icons that provide calling information and operating conditions.

Figure 29: Handset Display



A descriptions of the icons that appear in the handset display are provided in the following table.

Description of Icons in Handset Display

Icon	Description
	The Talk icon indicates a connection between the handset and base unit.
	The Mute icon indicates that the handset microphone is muted (that is, off).
	The Speaker icon indicates that the speakerphone is on.
	The Message Waiting icon indicates you have a message. See your System Administrator for instructions on how to retrieve your messages.
	The Ringer Off icon indicates that the handset ringer is off.
	The Battery icon indicates the current state of the handset's battery. When the icon reduces to one bar, return the handset to the charger unit or replace the handset battery with another charged battery.

Base Unit

The base unit can be mounted on a wall or placed on a desk. There is one blue power LED that indicates the base unit has power.

Figure 30: Base Unit

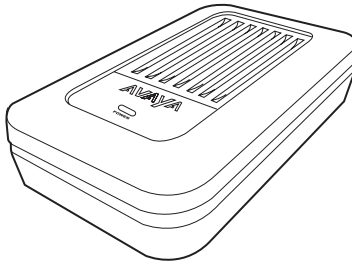

Charger Unit

The handset comes with a charger unit that functions as a cradle for the handset when in Standby Mode (or idle) and a charger for the handset battery. The charger unit also has a rear slot for spare battery charging. Two LEDs indicate the handset battery and spare battery are charging and making good contact with the charger unit.

Figure 31: Charger Unit

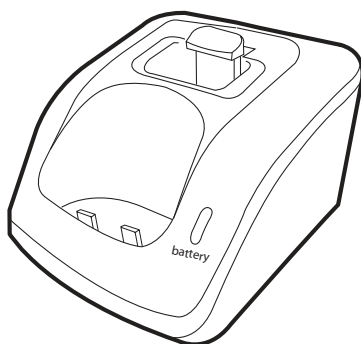

Clean the Charger Unit Contacts

It is important to clean all charging contacts on the charger unit and on the handset and spare battery about once a month. Use a pencil eraser or a soft dry cloth. Do not use any liquids or solvents.

Figure 32: Clean Charger Unit Contacts

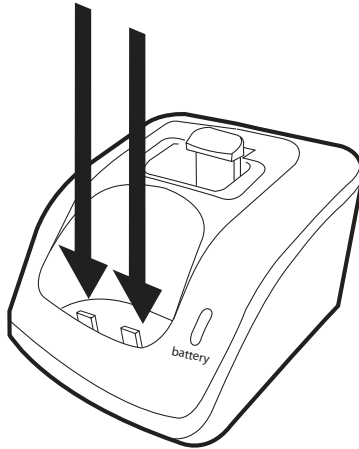

Battery

Your wireless telephone comes with one nickel-metal hydride rechargeable battery that provides up to 12 hours of talk time (fully charged).

Low Battery Indications

If the battery runs low while a call is in progress, the handset beeps once every three seconds.

If the battery is low while the telephone is in Standby Mode:

- Handset beeps every 15 seconds for 3 minutes
- None of the buttons operate
- Handset cannot make or receive calls
- Battery Charge icon indicates the current state of the handset's battery. When the icon reduces to one bar, return the handset to the cradle or swap the battery with a charged one.

It is recommended that you have a spare battery always charging to ensure against complete battery discharge. See [“Charge the Spare Battery” on page 28](#) for more information. To restore the battery capacity, return the handset to the charger unit for charging or replace the handset battery with a charged one. The battery can remain in the charger unit.

4 Using Your Telephone

Overview

This chapter describes the three handset modes and provides procedures on how to handle calls and change handset settings.

Handset Modes

There are three modes in which the handset operates:

- **AutoAnswer Mode.** When the handset is in the charger unit, it is in AutoAnswer mode. You are automatically connected to an incoming call when you remove the handset from the charger unit and automatically disconnected from the call when you place the handset back in the charger unit.
- **Standby Mode.** When the handset is out of the charger unit and not in use, it is in Standby mode. You must press **TALK** to answer an incoming call and to hang up.
- **Talk Mode.** When the handset is out of the charger unit and in use, it is in Talk mode. The Talk icon appears in the handset display.

Handling Calls

This section describes how to:

- Make and answer calls
- Place a call on hold
- Transfer a call
- Conference a call
- Mute a conversation

Make a Call

- 1 Press **TALK**.

NOTE 

Pressing the Speaker button when you are not active on a call also puts the handset offhook.

- 2 When you hear dial tone, enter the extension or telephone number using the dialpad.

If you want to turn on the speakerphone, press the Speakerphone button. Pressing this button toggles the speakerphone on and off.

- 3 When you are finished with the call, press **TALK** to hang up.

Answer a Call

- 1 Do one of the following:

- If the handset is out of the charger unit, press **TALK** to answer the call.
- If the handset is in the charger unit, pick up the handset to answer the call. You are automatically connected to the call.

If you want to turn on the speakerphone, press the Speakerphone button.

- 2 When you are finished with the call, press **TALK** to hang up.

Make an Intercom Call

- 1 Press the Intercom button.
- 2 When you hear dial tone, enter the extension number using the dialpad.
If you want to turn on the speakerphone, press the Speakerphone button.
- 3 When you are finished with the call, press **TALK** to hang up.

Answer an Intercom Call

- 1 Do one of the following:
 - If the handset is out of the charger unit, press **TALK** to answer the call.
 - If the handset is in the charger unit, pick up the handset to answer the call. You are automatically connected to the call.If you want to turn on the speakerphone, press the Speakerphone button.
- 2 When you are finished with the call, press **TALK** to hang up.

Place a Call on Hold

- 1 While on a call, press **HOLD**.
- 2 To resume a call, you must be in Talk mode. Press the button representing the call on hold.

Transfer a Call

- 1 While on a call, press **TRANSFER**.
- 2 When you hear dial tone, dial the extension or telephone number to which the call is being transferred.
- 3 Do one of the following:
 - To transfer the call without announcing it, press **TALK**.
 - To announce the call before transferring, wait for the called party to answer. When the called party answers, announce the call and press **TALK**.

Conference a Call

- 1 While on a call, press **CONF**.

NOTE 

Depending on your system, you will hear dial tone or you must select a line.

- 2 Select an Intercom button or line button, and dial the extension or telephone number.
- 3 When the other party answers, press **CONF** to have a three-way conversation.

Mute a Conversation

- 1 While on a call, press **MUTE**.
- 2 Press **MUTE** again to turn the handset speaker back on.

Changing Handset Settings

This section describes how to:

- Change the earpiece volume
- Change the ring type and volume
- Set Vibrate mode
- Turn the ringer off
- Set the End of Range alarm

Change Earpiece Volume

Press the **Vol +** and - buttons on the side of the handset during a call to change the earpiece volume on the handset.

Change Ring Type and Volume

Press the **Vol +** and - buttons on the side of the handset in Standby mode (the handset is out of the charger unit and not in use) to change the volume.

To change the ringer type:

- 1 Press **menu**.
- 2 Press **menu** again to select "Change Ringer Type."
- 3 Use the **Vol +** and - buttons to scroll up/down to select the desired ring tone. Each time you select a tone, the handset plays that tone. You can choose from six tones.
- 4 Press **menu** to set the ring tone.
The Saved message appears.
- 5 Use the **Vol +** and - buttons to select "Exit."
- 6 Press **menu**.

Set Vibrate Mode

- 1 Make sure the handset ringer is set to on.
- 2 Repeatedly press the **Vol +** button on the side of the handset until you feel the handset vibrate. **Ring Off (Vibrate)** will also appear in the handset display.

NOTE

If the handset is set to vibrate and the handset is in the charger unit when there is an incoming call, you will hear a low ring.

Turn Ringer Off

Press and hold the **Vol -** button on the side of the handset. The ringer off icon appears in the display.

Set Silent Alert

- 1 Turn the ringer off.
- 2 Place the handset in the charger unit. An incoming call is indicated in the handset display.

Set the End of Range Alarm

Use this procedure to set whether the handset will alert you when you move beyond the range of the base or repeater.

- 1 Press **menu**.
- 2 Use the **Vol +** and - buttons on the side of the handset to select "End of Range Alarm."
- 3 Press **menu**.
- 4 Use the **Vol +** and - buttons to select "On" or "Off."
- 5 Press **menu** to save your setting.
The system displays "Saved."
- 6 Use the **Vol +** and - buttons to select "Exit."
- 7 Press **menu**.

A Troubleshooting

If your Avaya 3920 Wireless Telephone is not performing to your expectations, try the suggestions provided in the following table. If you are still unable to resolve the problem, contact your telephone System Administrator.

NOTE ►

Do not attempt to service this unit yourself. All service must be done by qualified service personnel.

Condition	Suggestion
Indicator does not light when handset is placed in the charging cradle.	<p>Make sure the AC adapter is plugged into the charging cradle and wall outlet. If the AC adapter is plugged into a wall outlet with a switch, make sure the switch is turned on.</p> <p>Make sure the handset is properly seated in the charging cradle.</p> <p>Make sure the battery is properly seated in the handset.</p> <p>Make sure that the charging contacts on the handset and charging cradle are clean. Use a soft dry cloth to clean contacts. Do not use any liquids or solvents.</p>
The handset was properly seated in the charging cradle, but the battery did not charge properly.	<p>Remove the battery from the handset, and then place the battery in the rear slot on the charger unit to charge it. See “Charge the Spare Battery” on page 28.</p>

<p>Conversation is interrupted frequently.</p>	<p>Move back within the system range limit (for example, move closer to the base unit or a repeater.) Consider installing a repeater if you experience this condition frequently.</p>
<p>SEARCHING . . . or OUT OF RANGE appears in the handset display.</p>	<p>You may be at the range limit. Move back within the system range limit (for example, move closer to the base unit or a repeater.) Consider installing a repeater if you experience this condition frequently.</p> <p>Make sure there is power going to the base unit.</p> <p>Check the connection between the PARTNER system and the base unit.</p> <p>Determine the number associated with the telephone. Dial that telephone number from a “wired” telephone. If you hear busy tone, the base unit is not communicating with the PARTNER system. Perform the following steps:</p> <ul style="list-style-type: none"> • Check the power. • Verify that the telephone cord is connected to the base unit. • Make sure the handset is properly registered to the base. See the <i>Avaya 3920 Wireless Telephone Planning and Installation Guide</i> to register the handset with the base unit. • Verify that the installation guidelines have been followed, especially for systems where there are more than three Avaya 3920 Wireless Telephones.

ACQUIRING LINK appears in the handset display.	Make sure the telephone cord is seated properly in the base unit and in the wall jack.
Echo during conversation	<p>Depending on the environment from which you are calling, such as a noisy area, a caller may experience echo if the volume control of the handset is set too high. Try lowering the volume on your handset. If that does not help, contact your authorized dealer.</p> <p>If you are using the speakerphone, turn off the speakerphone and try using the handset's built-in microphone and ear piece.</p>
No dial tone.	<p>Move back within the system range limit (for example, move closer to the base unit or a repeater.) Consider installing a repeater if you experience this condition frequently.</p> <p>Confirm that the telephone has been administered properly. See the <i>Avaya 3920 Wireless Telephone Planning and Installation Guide</i> for more information.</p>
Handset does not ring.	<p>The battery could be weak. Charge the battery for 16 to 20 hours.</p> <p>Check the Ringer Switch; it could be turned off.</p> <p>Make sure the ringer is not set to vibrate.</p> <p>Move back within the system range limit (for example, move closer to the base unit or a repeater.) Consider installing a repeater if you experience this condition frequently.</p>
An underscore replaces a character in the handset display.	The telephone does not recognize special characters (for example, punctuation marks) that are provided from the PARTNER system.

Telephone rings but there is no visual indication on the handset that there is an incoming call.	Confirm that the telephone has been administered properly. See the <i>Avaya 3920 Wireless Telephone Planning and Installation Guide</i> for information on administering the Avaya 3920.
You hear one or more beeps periodically.	You are using repeaters, and the repeater confirmation tone is turned on. See the <i>Avaya 3920 Wireless Telephone Planning and Installation Guide</i> to change the confirmation tone setting.
Cannot resume a call that was put on Hold.	Confirm that the telephone has been administered properly. See the <i>Avaya 3920 Wireless Telephone Planning and Installation Guide</i> for information on administering the Avaya 3920.

B Specifications

Specifications	
Base Unit	
Operating Temperature	0° to 50° C (32° F to 122° F)
Receive/Transmit Frequency	1920 MHz to 1930 MHz
Peak RF Output/Transmit Power	100 mW (+20 dBm)
Power Requirements	120V from supplied AC adapter
Size	Width – 14 4/5 inches Depth – 10 4/5 inches Height – 4 2/5 inches
Weight	Approximately 14.3 oz.
Handset	
Operating Temperature	0° to 50° C (32° F to 122° F)
Receive/Transmit Frequency	1920 MHz to 1930 MHz
Power Requirements	Nickel Metal-Hydride rechargeable battery
Size	Width – 2 1/5 inches Depth – 1 2/3 inches Height – 6 1/4 inches
Weight	Approximately 5.4 oz. with battery
Battery	Capacity – 910 mAh, 2.4 V Talk Time – 12 hours Standby Time – 6 days

Specifications	
Repeater	
Operating Temperature	0° to 50° C (32° F to 122° F) NOTE  <i>The repeater has an IP54 (weather resistant) weather protection rating. The repeater is protected against dust and weather hazards (such as rain and sleet) and sprayed oil and noncorrosive coolants.</i>
Receive/Transmit Frequency	1920 MHz to 1930 MHz
Peak RF Output/Transmit Power	100 mW (+20 dBm)
Power Requirements	120V from supplied AC adapter
Size	Width – 4 1/2 inches Depth – 1 1/5 inches Height – 5 3/10 inches
Weight	Approximately 5 oz.

C Accessories

A list of accessories for the Avaya 3920 Wireless Telephone is provided in the following table. To order an accessory, contact your local Authorized Dealer or go to www.unidendirect.com/avaya.

Accessory Description
Repeater Programming Kit
BBTG0658001 Battery for Handset
BZAG0133001 Boom Microphone Earset
HS910BPB Over-the-Head Headset
HS915 Headphone-style Headset
AP680BHXA Belt Clip
Leather Carrying Case
BADG0962001 AC Adapter for Charger
AP680BHC Charger (without AC Adapter)
BADG0961001 AC Adapter for Base Unit
EXP9660 Wall Mount Plate
AP680BHP-AV Handset
PLBM468985Z Handset Rear Phone Number Paper
KDPZ468991A Handset Rear Phone Number Paper Plastic Cover
PLBM4D4331Z Handset Front Index Paper
KDPZ4D4330Z Handset Front Index Paper Plastic Cover

